



# **MBL Series Evaluation Kit User Manual**

**Next-generation package-compatible Sub-1G wireless module**

**E77-900MBL-01**



<b>1 PRODUCT OVERVIEW .....</b>	<b>2</b>
1.1 PRODUCT INTRODUCTION .....	2
1.2 DIMENSIONS, INTERFACE DESCRIPTION .....	2
1.3 SUPPORT MATRIX .....	4
<b>2: QUICK PRESENTATION .....</b>	<b>5</b>
2.1 SIGNAL CABLE CONNECTION .....	5
2.2 SERIAL PORT ASSISTANT .....	5
<b>3 FREQUENTLY ASKED QUESTIONS .....</b>	<b>7</b>
3.1 THE TRANSMISSION DISTANCE IS NOT IDEAL .....	7
3.2 MODULES ARE EASILY DAMAGED .....	7
3.3 THE BIT ERROR RATE IS TOO HIGH .....	7
<b>REVISION HISTORY .....</b>	<b>8</b>
<b>ABOUT US .....</b>	<b>8</b>

# 1 Product Overview

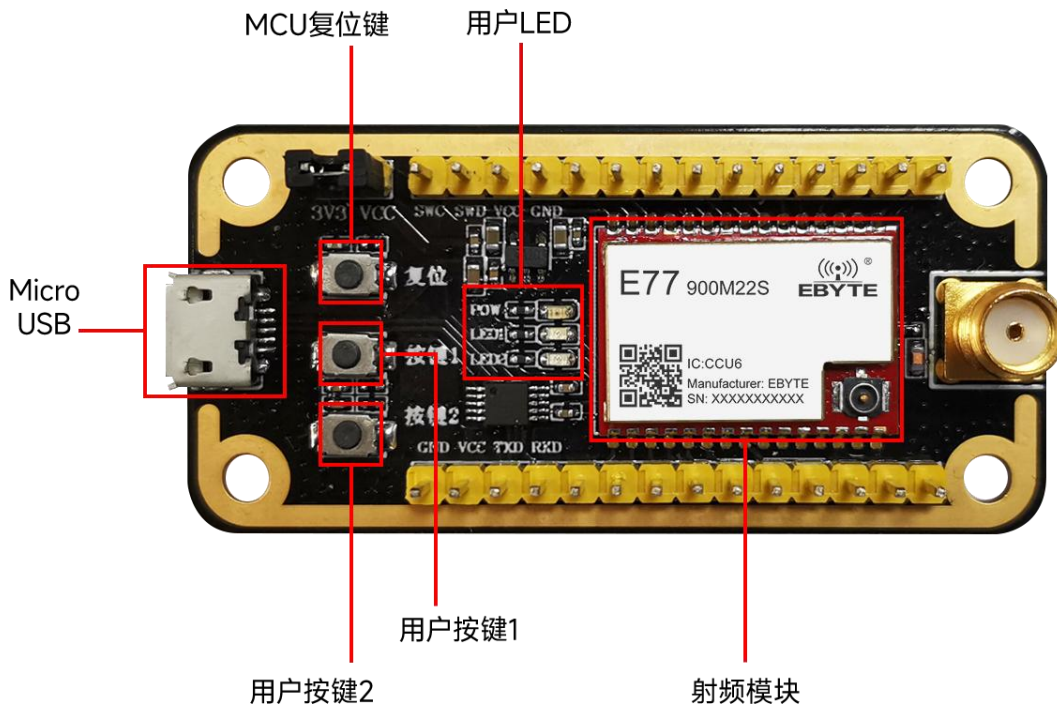

## 1.1 Product Introduction

The MBL series evaluation kits are designed to help users quickly evaluate Ebyte's next-generation package-compatible wireless modules. Most of the pins on the board are led out to the pin headers on both sides, making it easy for developers to connect a variety of peripherals via jumpers to their needs.

The kit provides complete software application examples to help customers get started quickly with wireless data communication development. Different types of Sub-1G wireless modules can be installed on-board according to customer needs. Supported modules are available in pin-compatible packages for quick replacement.

## 1.2 Dimensions, interface description

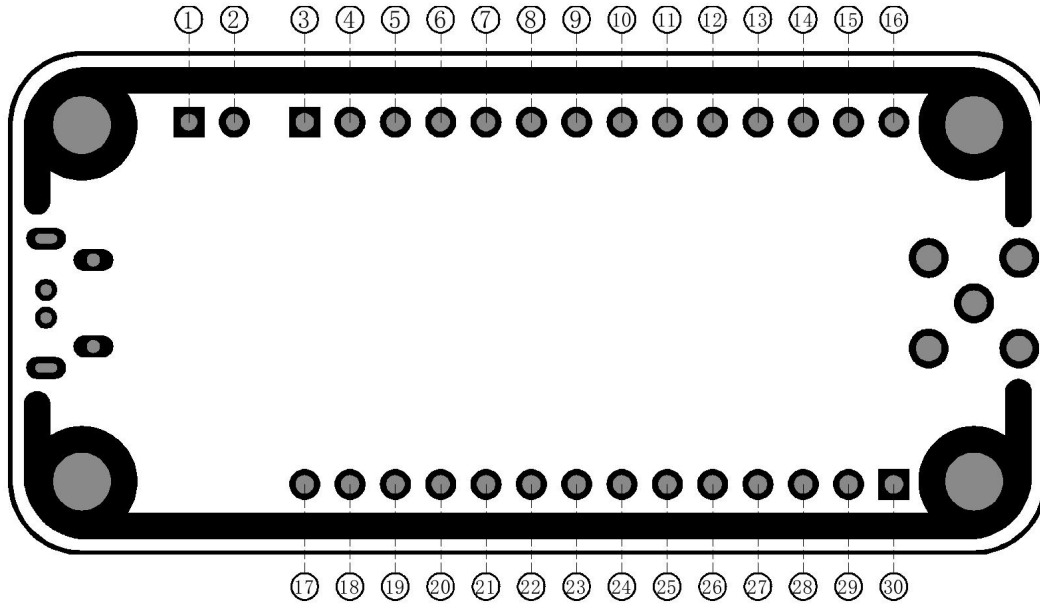

PIN	Defi	Description
1	3.3V	The 3.3V supply leads the pin
2	VCC	The module power supply pin needs to be shorted to pin 1 to power the module
3	REST	The MCU external reset pin
4	SWCLK	SWCLK pin of the MCU
5	SWDIO	SWDIO pin of the MCU
6	GND	Baseplate reference ground
7	PC13	Module Normal IO
8	PA15	Module Normal IO
9	PB0	Module Normal IO
10	PB2	Module Normal IO
11	PB12	Module Normal IO
12	PA10	Module Normal IO
13	PA11	Module Normal IO
14	PA12	Module Normal IO
15	PA9	Module Normal IO
16	PA8	Module Normal IO
17	GND	Baseplate reference ground
18	3.3V	The 3.3V supply leads the pin
19	TXD	Module low-power serial port TXD
20	RXD	Module low-power serial port RXD
21	PB3	Module Normal IO
22	PB4	Module Normal IO
23	PB5	Module Normal IO
24	PB6	Module Normal IO
25	PB7	Module Normal IO

26	PB8	Module Normal IO
27	PA0	Module Normal IO
28	PA1	Module Normal IO
29	PA4	Module Normal IO
30	PA5	Module Normal IO

### 1.3 Support matrix

	<b>RF solutions</b>	<b>manufacturer</b>	<b>Module model</b>
1	STM32WLE5CCU6	STMicroelectronics	E77-400M22S
2	STM32WLE5CCU6	STMicroelectronics	E77-900M22S

## 2: Quick Presentation

### 2.1 Signal cable connection

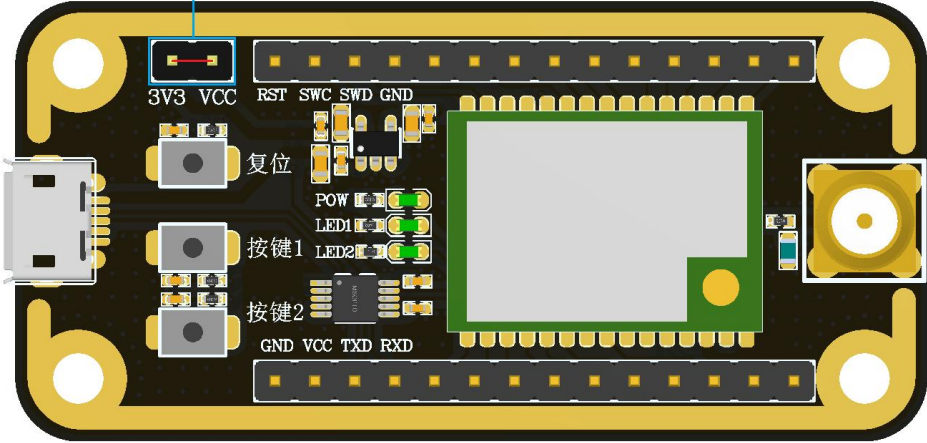
	Item	Description
1	Power jumper cap	<p>模块电流测试排针，使用跳线帽按图示方向短接排针</p> 
2	auxiliary	USB cables, antennas, PCs, etc

### 2.2 Serial port assistant

	Item	Description
1	Device Manager Check the serial port number	

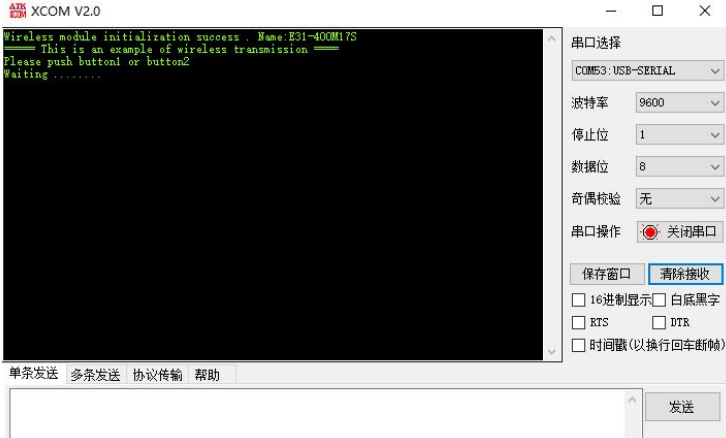
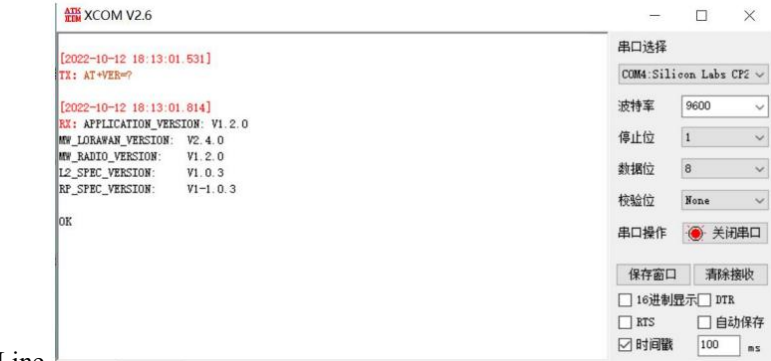
<p>2</p>	<p>Serial port software</p>	
<p>3</p>	<p>Communication example</p>	<p>Use the AT command to read the version number to see if the module is connected normally, and the AT command needs to check Send New</p>  <p>Line.</p>

For more information on how to use it, please refer to the module product application note.

## 3 Frequently Asked Questions

### 3.1 The transmission distance is not ideal

- When there is a linear communication obstacle, the communication distance will be attenuated accordingly;
- Temperature, humidity, and co-channel interference will lead to an increase in the packet loss rate of communication;
- The ground absorbs and reflects radio waves, and the test effect near the ground is poor;
- Seawater has a strong ability to absorb radio waves, so the seaside test effect is poor;
- If there is a metal object near the antenna, or placed in a metal case, the signal attenuation will be very serious;
- The power register is set incorrectly, and the air rate is set too high (the higher the air rate, the closer the distance);
- The low voltage of the power supply at room temperature is lower than the recommended value, and the lower the voltage, the smaller the power;
- The use of antennas is poorly matched with the module or the quality of the antenna itself.

### 3.2 Modules are easily damaged

- Please check the power supply to ensure that between the recommended supply voltage, if the maximum value is exceeded, it will cause permanent damage to the module;
- Please check the stability of the power supply, the voltage should not fluctuate greatly and frequently;
- Please ensure that the installation and use process of anti-static operation, high-frequency devices electrostatic sensitivity;
- Please ensure that the humidity during installation and use should not be too high, and some components are humidity sensitive devices;
- If there is no special need, it is not recommended to use it at too high or too low temperature.

### 3.3 The bit error rate is too high

- There is co-channel signal interference nearby, stay away from the interference source or modify the frequency and channel to avoid interference;
- Unsatisfactory power supply may also cause garbled characters, be sure to ensure the reliability of the power supply;
- Poor quality or too long extension wires and feeders will also cause high bit error rates.



## Revision history

Version	Date	Description	Maintainer
1.0	2022-12-30	Initial version	HWJ

## About us

Technical support: [support@cdebyte.com](mailto:support@cdebyte.com)

Documents and RF Setting download link: <https://www.cdebyte.com>

Thank you for using Ebyte products! Please contact us with any questions or suggestions: [info@cdebyte.com](mailto:info@cdebyte.com)

-----  
Phone: +86 028-61399028

Web: <https://www.cdebyte.com>

Address: B5 Mould Park, 199# Xiqu Ave, High-tech District, Sichuan, China

 **Chengdu Ebyte Electronic Technology Co.,Ltd.**