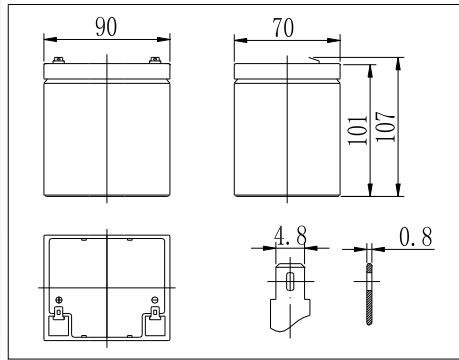

Dimensions

Specifications

Nominal Voltage		12 V
Capacity(20HR, 25°C)		5.5 Ah
Dimension	Length	90mm (3.54inch)
	Width	70mm (2.76inch)
	Height	101mm (3.98inch)
	Total Height	107mm (4.21inch)
Approx. Weight		1.8kg (3.97lbs)
Internal resistance (Fully charged, 25°C)		Approx. 34m
Capacity affected by temperature (20HR)	40°C	102%
	25°C	100%
	0°C	85%
	-15°C	65%
Self-discharge (25°C)	3 month	Remaining Capacity: 91%
	6 month	Remaining Capacity: 82%
	12 month	Remaining Capacity: 65%
Nominal operating temperature		25°C °C (77°F 5°F)
Operating temperature range		-15°C 50°C (5°F 122°F)
Float charging voltage(25°C)		13.60 to 13.80V
Cyclic charging voltage(25°C)		14.50 to 14.90V
Maximum charging current		1.5A
Terminal material		Copper
Maximum discharge current		90A(5 sec.)

AGM and VRLA technology;

Recognized by UL & CE;

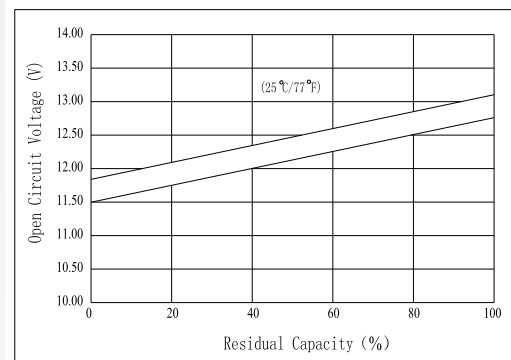
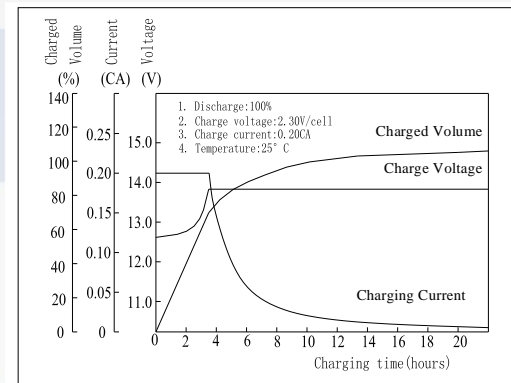
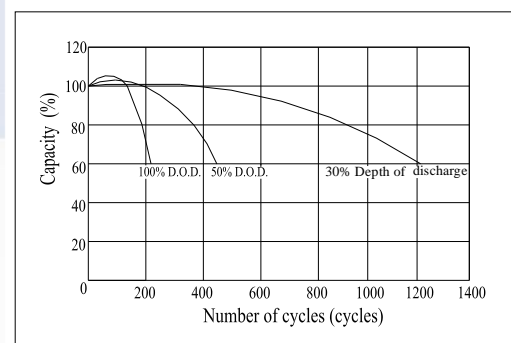
ABS container. Orange, Blue or Black Color.

The Relationship for Open Circuit Voltage and Residual Capacity (25°C)

Charging Characteristics(25°C)

Cycle Life(25°C)

Note: Floating life at 20°C designed for 5 years.

Constant Current Discharge Characteristics (A, 25°C)

F.V/TIME	5min	10min	15min	30min	60min	3h	5h	10h	20h
9.60V	25.5	16.0	12.5	6.8	3.9	1.47	0.97	0.52	0.30
10.2V	24.2	15.2	12.0	6.53	3.74	1.45	0.96	0.52	0.30
10.8V	22.8	14.3	11.4	6.20	3.56	1.42	0.94	0.51	0.28

Constant Power Discharge Characteristics (Watt, 25°C)

F.V/TIME	5min	10min	15min	30min	60min	3h	5h	10h	20h
9.60V	285	180	143	77.9	45.2	17.5	11.6	6.24	3.60
10.2V	270	171	137	74.8	43.4	17.2	11.5	6.24	3.60
10.8V	254	161	130	71.1	41.2	16.9	11.2	6.12	3.36