INSTRUCTION MANUAL

UV RAYS

TYPE RS485

JXBS-3001-UV

VER1.1

I BRIEF INTRODUCTION

1.1 Product Overview

This product adopts high sensitivity photosensitive probe, the signal is stable and the precision is high. It has the characteristics of wide measurement range, good linear degree, good waterproof performance, convenient use, easy installation and long transmission distance.

1.2 Primary Parameters

PARAMETERS	TECHNICAL SPECIFICATIONS
POWER SUPPLY	12-24V DC
POWER	0.4W
OUTPUT SIGNAL	RS485
UV ACCURACY	±3% (25°C)
UV MEASUREMENT RANGE	0-150W/m ²
HUMIDITY RANGE	0%RH-100%RH
TEMPERATURE RANGE	-40°C-80°C
UV LONG-TERM STABILITY	≤5%/y
POWER CONSUMPTION	≤0.15W(@12V DC , 25°C)
WORKING PRESSURE RANGE	0.9-1.1atm

1.3 UV Parameters

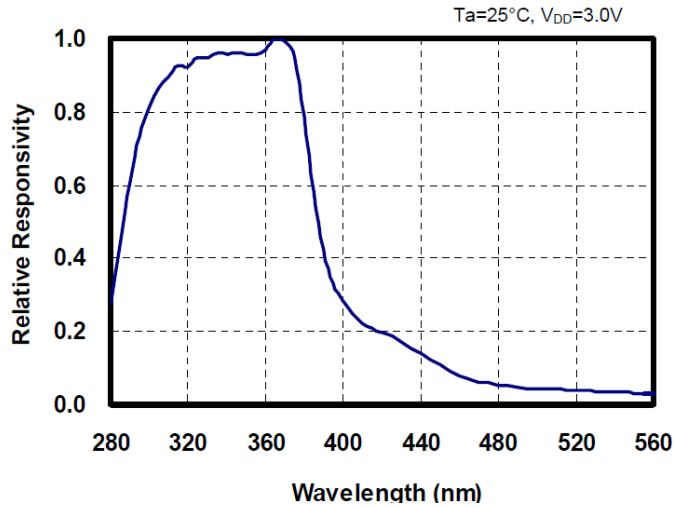

Figure 1. Influence of different wavelengths on UV intensity

As shown in Figure 1, the wavelength is most accurate around 370nm and the scale factor is 1.

1.4 Temperature and humidity parameters

PARAMETERS	CONTENT
HUMIDITY PRECISION	±3%RH (0%RH-100%RH,25°C)
TEMPERATURE PRECISION	±0.5°C (25°C)
HUMIDITY RANGE	0%RH-100%RH
TEMPERATURE RANGE	-25°C-+85°C
LONG-TERM STABILITY OF TEMPERATURE	≤0.1°C/y
LONG-TERM STABILITY OF HUMIDITY	≤1%/y
HUMIDITY RANGE	0%RH-100%RH
TEMPERATURE RANGE	-40°C-80°C
LONG-TERM STABILITY OF TEMPERATURE	≤0.1°C/y
LONG-TERM STABILITY OF HUMIDITY	≤1%/y

1.5 Temperature Parameters

CONTENT	Minimum	Typical value	Maximum	Unit
Resolution (14bit)	-	0.01	-	°C
Linear deviation	-	±0.3	Figure 2	°C
Repeatability	-	±0.1	-	°C
The scope of work	-40	-	125	°C
Response time (63%)	5	-	30	second
Long-term drift	-	<0.04	-	°C/year

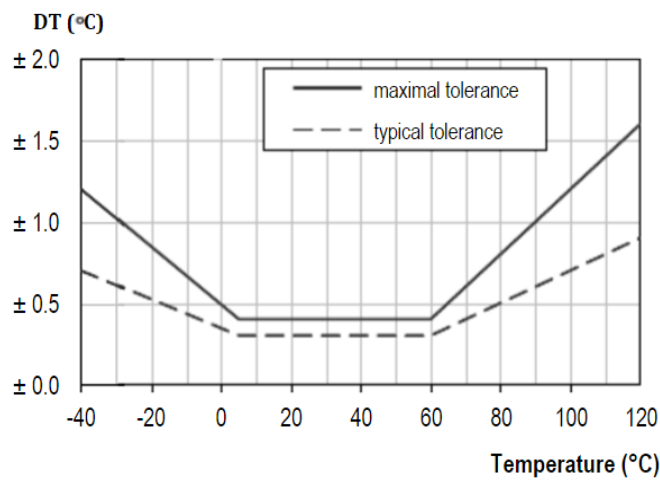

Figure2 Temperature measurement accuracy at different temperatures

As shown in the above table, the maximum deviation is within ± 0.5 in the range of 5-60 degrees Celsius, and the deviation increases with less than 0 degrees Celsius and greater than 60 degrees Celsius.

1.6 Humidity Parameter

CONTENT	Minimum	Typical value	Maximum	Unit
Resolution (12bit)	-	0.04	-	%RH
Linear deviation	-	±3.0	Figure 3	%RH
Repeatability	-	±0.1	-	%RH

The scope of work	0	-	100	%RH
Response time (63%)	-	8	-	second
Long-term drift	-	<0.5	-	%RH /year
Hysteresis	-	±1	-	%RH
Non-linearity	-	<0.1	-	%RH

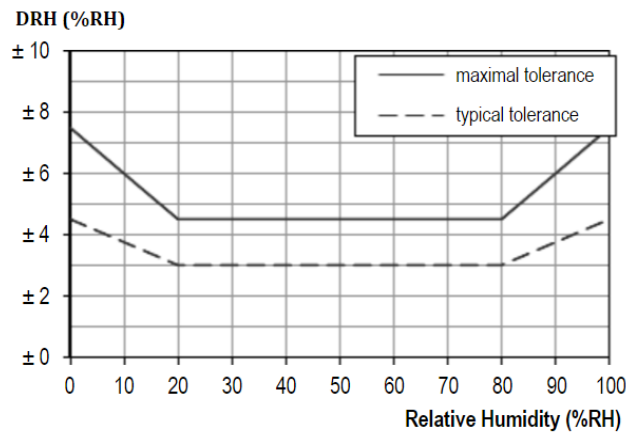

Figure3 Humidity measurement accuracy under different humidity conditions

As shown in the above table, the deviation increases with a typical deviation of ±3% in the 20-80% RH range, less than 20%, and greater than 80% humidity.

1.7 Influence of temperature on humidity measurement

Figure 2 describes the effects of different humidity conditions on the humidity measurement. The following table describes the effects of different temperatures on the humidity measurement accuracy.

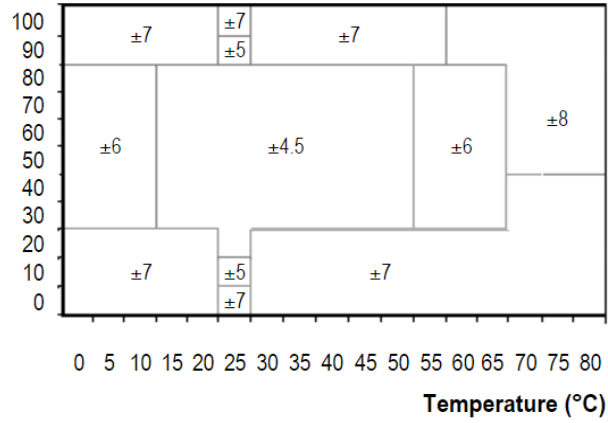

Figure 4 Relative humidity at different temperatures

As shown in the above table, in the range of 15 to 55 degrees Celsius and 30 to 80 degrees of humidity, the accuracy of humidity is the highest, which is $\pm 4.5\%$. In other cases, the humidity increases.

1.8 System frame Diagram

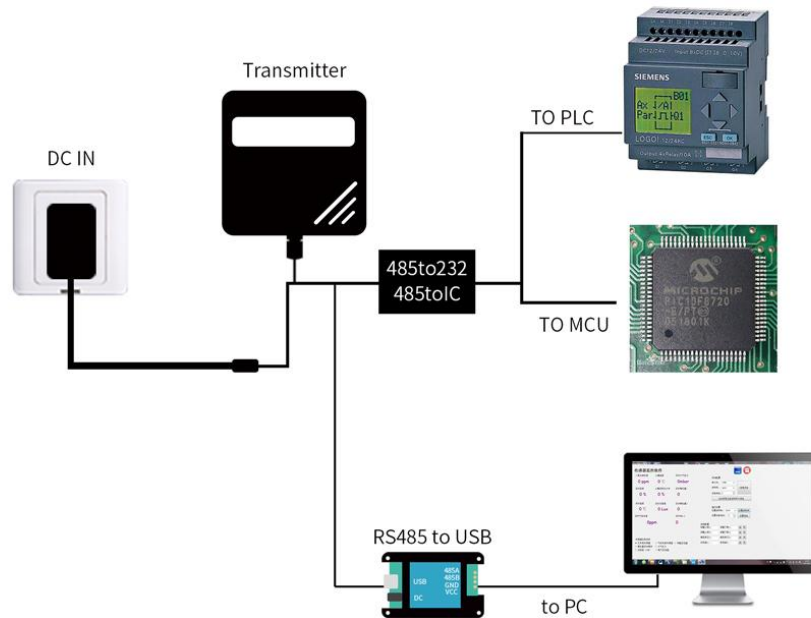

FIGURE 5 SINGLE-ENDED

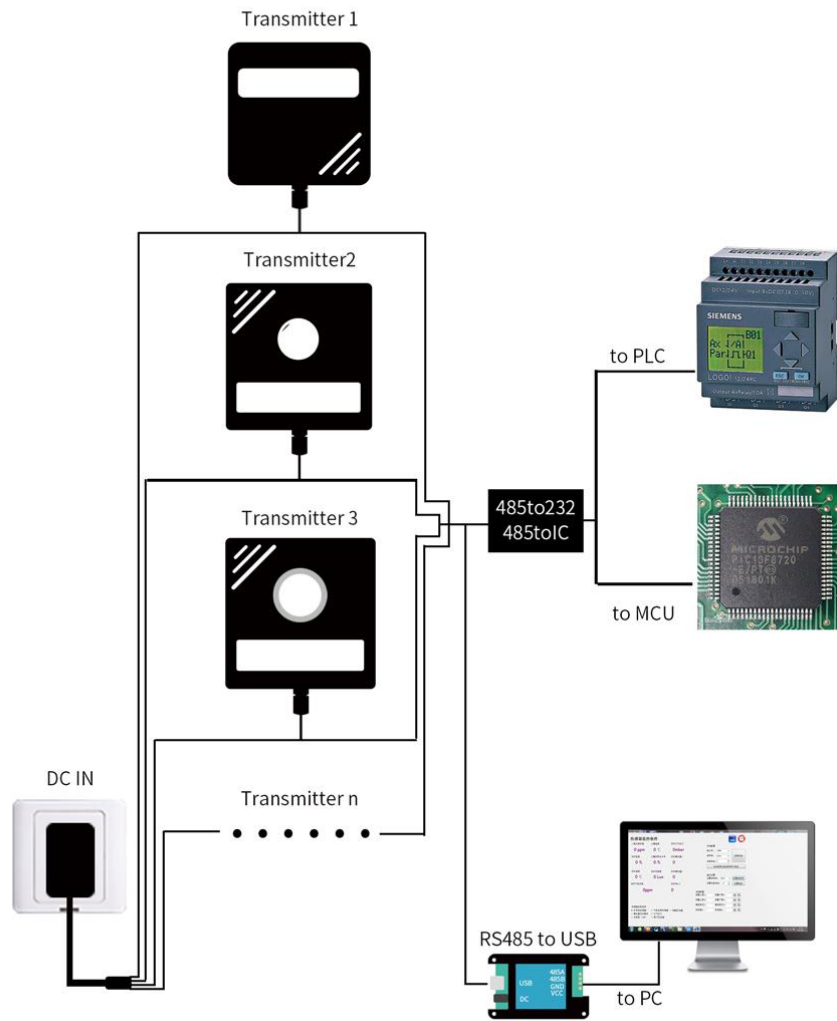

FIGURE 6 MUTIPLE-ENDED

II HARDWARE CONNECTIONS

2.1 CHECKING BEFORE INSTALLATION

Check the list of devices before installation:

TABLE 1 List of Devices

Name	Number
THE SENSOR DEVICE	1
12V POWER ADAPTER (Optional)	1
WARRANTY CARD / CERTIFICATE	1
THE USB TO 485 DEVICE (Optional)	1

2.2 Interface Description

The power interface is wide voltage input 12-24V. When connecting the 485 signal cable, note that the A/B lines cannot be reversed. The addresses of multiple devices on the bus cannot conflict.

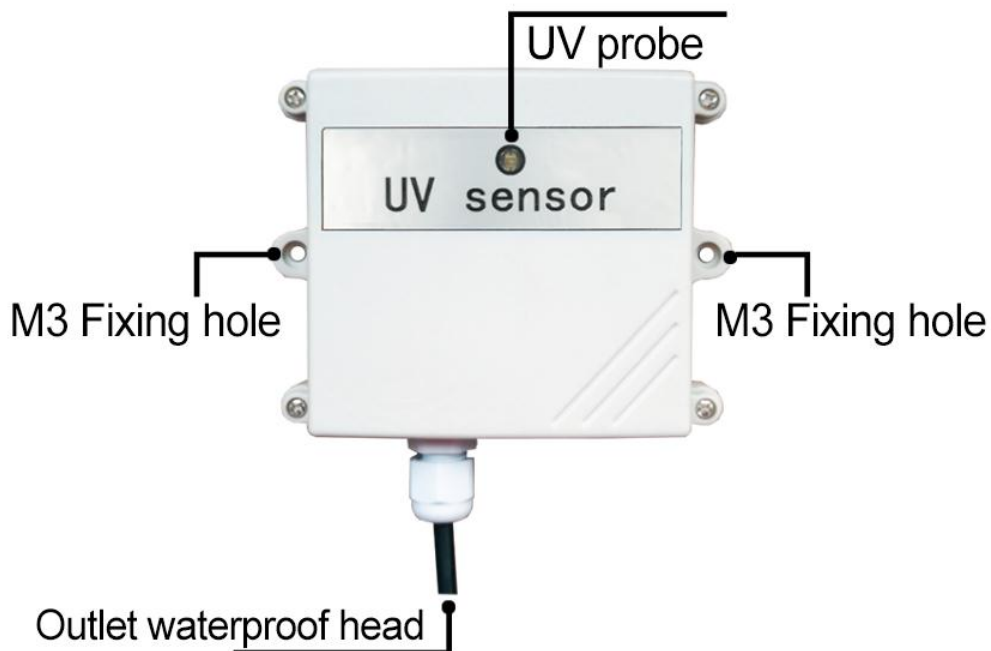

FIGURE 7 PHYSICAL PICTURE

TABLE 2 Wiring Sequence

	Line Color	Description
Power	Brown	Power supply Positive (12-24V DC)
	Black	Power supply Negative
Communication	Yellow	485-A
	Blue	485-B

Precautions: Please take care not to take the wrong line sequence, the wrong wiring will cause the equipment to burn.

The factory default is to provide 0.6 meters long wire rods. Customers can extend the wire rods as required or sequentially.

Note that there are no yellow lines in the wire sequences that may be provided in some factory batches, in which case the gray line is equivalent to replacing the yellow line.

2.3 Installation

Ultraviolet transmitters are greatly affected by the angle of incidence, so the following two mounting options are recommended:

1. Install horizontally with the ground plane so that the sensory position is facing the sky. All-day measurements can be made as a fixed location.
2. If you want to measure the current real-time UV intensity, you can make the photo-sensing position directly opposite to the incident position of sunlight.

III CONFIGURATION TOOL

INSTALLATION AND USE

We provide **CONFIGURATION TOOL** , which can be easily used to test our sensor device.

3.1 Sensor Access Computer

Transmitter can be connected to PC with the RS485 to USB adapter. You can check the COM port number through Device Manager (right click My Computer).

3.2 How To Use Configuration Tool

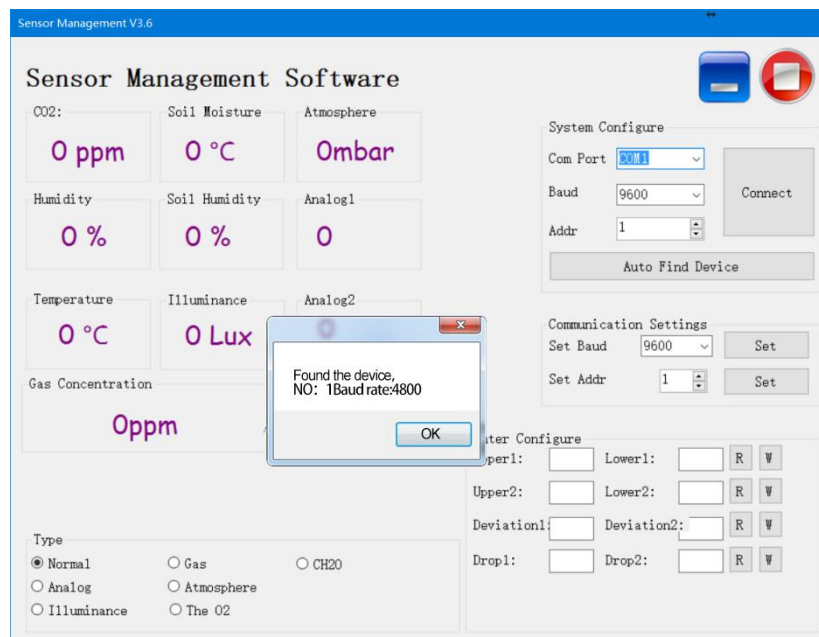

Please note that this software can only test one device at the same time. After connecting the physical device, click the **CONNECT** button to read the information.

In the UNCONNECT state, you can modify BAUD and ADDR in COMMUNICATION

SETTINGS.

Under the software, different check boxes can be selected according to different situations. For example, you can choose the GAS option to test the RS485 OXYGEN SENSOR , you can choose the NORMAL option to test the RS485 TEMPERATURE AND HUMIDITY SENSOR .

IV COMMUNICATION PROTOCOL

4.1 Communication Basic Parameters

TABLE 3 Communication Basic Parameters

PARAMETERS	CONTENT
Protocol	Modbus RTU
Data bits	8 bit
Parity bit	No
Stop bit	1 bit
Error checking	CRC (redundant loop code)
Baud rate	2400 bps/ 4800 bps/ 9600 bps can be set factory defaults to 9600 bps

For more information about **MODBUS RTU** please visit the website "www.modbus.org".

4.2 Register Address

Register Address	Plc Configuration Address	Content	Operation
0000H	40001	Humidity(unit 0.1%RH)	Read-Only
0001H	40002	Temperature(unit 0.1°C)	Read-Only
0008H	40009	UV Rays (unit0.1W/m ²)	Read-Only
0100H	40101	Device Address (0-252)	R/W
0101H	40102	Baud Rate (2400/4800/9600)	R/W

TABLE 4 Register Address

4.3 Communication example

4.3.1 Read Device Address 0x01's UV Value

TABLE 5 Inquiry Frame

Address Code	Function Code	Start Address	Data Length	CRC_L	CRC_H
0x01	0x03	0x00 0x08	0x00 0x01	0x05	0xC8

TABLE 6 Answer Frames

(For example, the reading is 68.0W/m²)

Address Code	Function Code	Returns to The Number Of Valid Bytes	Carbon Dioxide Value	Check Digit Low	Check Digit High
0x01	0x03	0x02	0x02 0xA8	0xB8	0x9A

UV :

02A8 H(hexadecimal)=680=>UV=68.0W/m²

4.3.2 Read Device Address 0x01's Temperature And Humidity Value

TABLE 7 Inquiry Frame

Address Code	Function Code	Start Address	Data Length	CRC_L	CRC_H
0x01	0x03	0x00,0x00	0x00,0x02	0xC4	0x0B

TABLE 8 Answer Frames

Address Code	Function Code	Number Of Valid Bytes	Humidity Value	Temperature Value	CRC_L	CRC_H
0x01	0x03	0x04	0x02	0xFF	0x5A	0x3D
			0x92	0x9B		

Temperature :

FF9BH (hexadecimal) =-101=> temperature =-10.1°C

Humidity:

292H(hexadecimal) =658=>humidity =65.8%RH

4.3.3 Read Device Address 0x01's UV, Temperature And Humidity Value

TABLE 9 Inquiry Frame

Address Code	Function Code	Start Address	Data Length	CRC_L	CRC_H
--------------	---------------	---------------	-------------	-------	-------

0x01	0x03	0x00,0x00	0x00,0x09	0x85	0xCC
------	------	-----------	-----------	------	------

TABLE 10 Answer Frame

Address Code	Function Code	Number Of Bytes	Humidity Value	Temperature Value
0x01	0x03	0x12	0x02 0x92	0x01 0x1C
12 Useless Bytes			UV value	Check code
00			0x02 0xA8	0x33 0x4B

UV :

02A8 H(hexadecimal)=680=>UV=68.0W/m²

Temperature :

011C H(hexadecimal)=284=>Temperature=28.4°C

Humidity :

0292 H(hexadecimal)=658=>Humidity=65.8%RH